

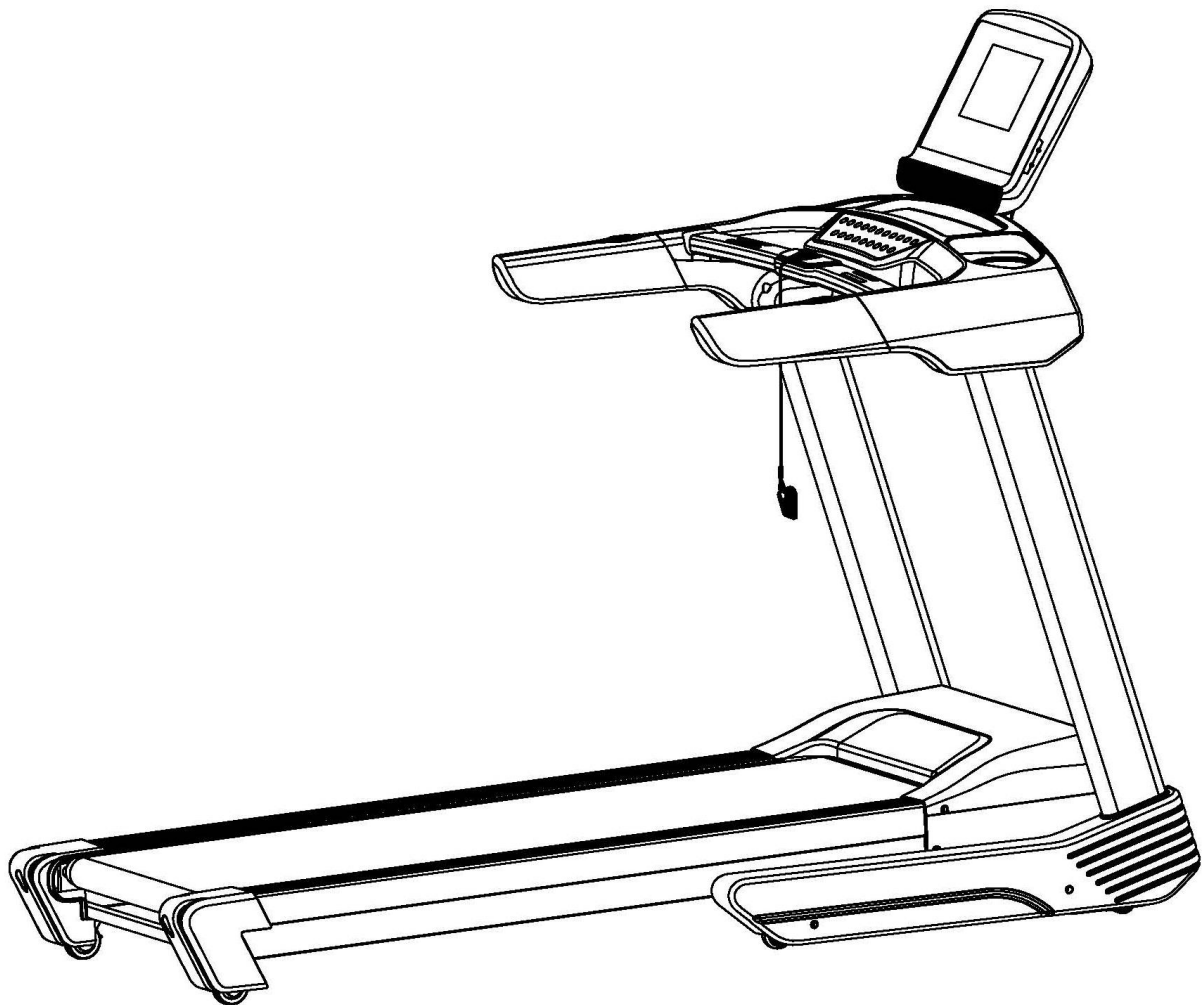

D.C. ATHLETICS®

Performance 7.0 MANUAL



WARNING

Read all instructions carefully before using this product. Retain this owner's manual for future reference:

----When using this treadmill, keep attaching the safety pull pin rope to your clothes.

----When you are running, keep your hand swinging natural, stare forward, never look down at your feet.

----Add the speed step by step when running.

----When emergency happens, take away the "emergent stop button" immediately.

----Leave the treadmill after the running belt stop stably.

Caution: Read the assembly instruction carefully, follow the instruction when assemble.

ATTENTION

01- Before starting any exercise program, consult with your physician or health professional.

02- Check all the bolts locked.

03- Never put the treadmill in the wetness area, or it will cause troubles.

04- We take no responsibility for any troubles or hurts due to above reasons.

05- Dress sport clothes and shoes before running.

06- Do not do exercise in 40 minutes after meal.

07- To prevent hurts, please warm up before exercise.

08- Consult with doctor before exercise if you have high blood pressure.

09- The treadmill is only used for adults.

10- Provide the olds, children and handicapped with good care, guide and supervision.

11- Do not plug anything into any parts of this equipment, or it may damage.

12- Do not connect line to the middle of cable; do not lengthen cable or change the cable plug; do not put any heavy thing on cable or put the cable near the heat source; forbid using socket with several holes, these may cause fire or people may be hurt by the power.

13- Cut off the power when the equipment is not used. When the power is cut off, do not pull the power line to keep the wire unbroken.

14. Maximum weight of user: **150 KGS.**

15. Pulse monitor data may not be accurate, can not be used for medicine. Over-exercise may cause injury, even death. If you have a feeling of dizziness, sickness or other abnormal symptoms, please stop

training and consult a doctor immediately.

IMPORTANT SAFETY PRECAUTION

1. Plug the power cord of the treadmill directly into a dedicated grounded circuit. This product must be grounded. If it has breakdown, grounding provides a path of least resistance for electric current to reduce the risk of electric shock.
2. Position the treadmill on a clear, level surface. Do not place the treadmill on thick carpet as it may interfere with proper ventilation. Do not place the treadmill near water or outdoors.
3. Position treadmill so that the wall plug is visible and accessible.
4. Never start the treadmill while you are standing on the walking belt. After turning the power on and adjusting the speed control, there may be a pause before the walking belt begins to move, always stand on the foot rails on the sides of the frame until the belt is moving.
5. Wear appropriate clothing when exercising on the treadmill. Do not wear long, loose fitting clothing that may be caught in the treadmill. Always wear running or aerobic shoes with rubber soles.
6. Make sure the power supply is connected and the safety lock is effective before using the treadmill. Fit one side of the safety lock on the treadmill and clip the other side on your clothes or belt, which will enable you to pull off the safety lock promptly in an emergency.
7. Always unplug the power cord before remove the treadmill motor cover.
8. Make sure there is no less than 2*1m space behind the treadmill.
9. Keep small children away from the treadmill during operation.
10. Always hold the handrails when initially walking or running on the treadmill, until you are comfortable with the use of the treadmill.
10. Always attach the safety pull pin rope to your clothing when using the treadmill. If the treadmill should suddenly increase in speed due to an electronics failure or the speed being inadvertently increased, the treadmill will come to a sudden stop when the pull pin is disengaged from the console.
12. In case of any abnormality during the use process, please remove the safety lock immediately, grasping the handlebar and jumping onto the two edgings, then get off the treadmill after it stops.
13. When the treadmill is not being used, the power cord should be unplugged and the safety pull pin removed.
14. Put the safety key away where can not be reached by the children. Minors must be accompanied by the adults when using the treadmill.
15. Before starting any exercise program, consult with your physician or health professional. He or she can help establish the exercise frequency, intensity (target heart zone) and time appropriate for your particular age and condition. If you have any pain or tightness in your chest, an irregular heartbeat, shortness of breath, feel faint or have any discomfort while you exercise, STOP! Consult your physician before continuing.
16. If you observe any damage or wear on the mains plug or on any section of the mains lead then please have these replaced immediately by a qualified electrician – do not attempt to change or repair these yourself.

17. If the supply cord is damaged, it must be replaced by the manufacturer, its service agent or similarly qualified persons in order to avoid a hazard.

18. Put your feet on the side rail before using the treadmill, and always attach the safety pull pin rope to your clothing. Hold the handle bar before the running belt moving well (feel the running speed by your single foot before using it). To avoid loss balance, please slow down the speed to the lowest or take off the safety. And hold the handle bar to jump to the side rail when emergency or the safety key is not attached.

19. Make sure the treadmill has stopped before folding. Please don't operate it after folding the treadmill.

ASSEMBLY STEPS

STEP 1:

Open the package, take out all parts and place the main frame on the flat ground.

(NOTE: Please don't cut down the packing straps right now.)

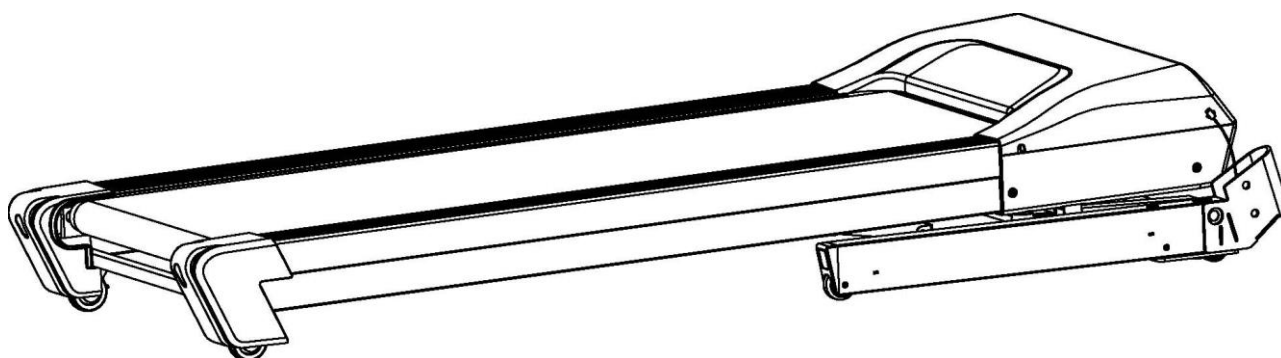

STEP 2:

1. Cut down the straps when the main frame was place well (NOTE:Don't move it any more)
2. Connect the Controller wire (95) and Extension lower wire (96).
3. Lock the upright tube (3L/R) on the bottom frame (1) with the hex socket screws (53), hex bolt (57) and the Lock washer (83).

NOTE: please don't tighten the Hex socket screw (53) and hex bolt (57) for the time being.

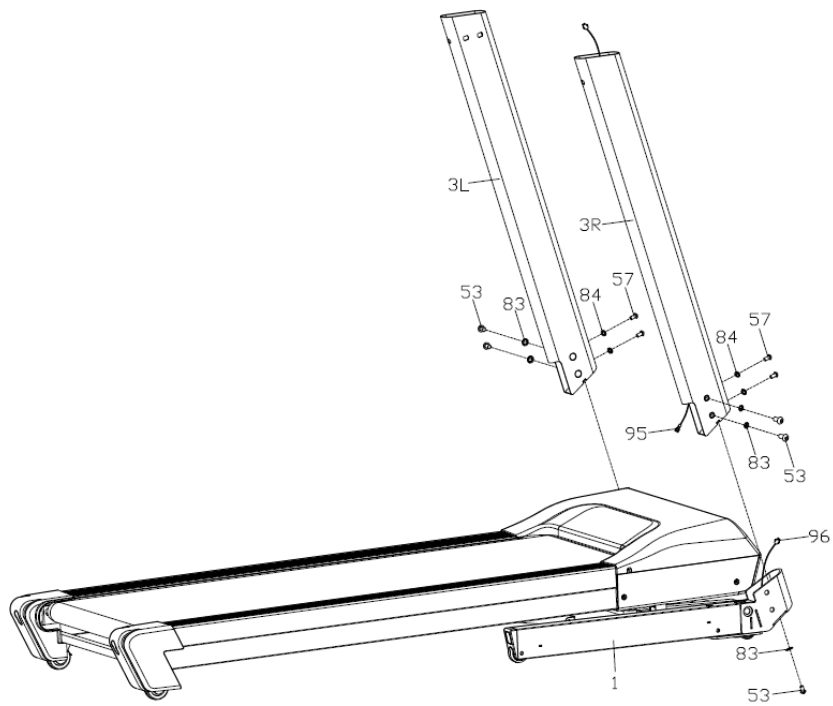

STEP 3:

1. Connect the extension upper wire (94) and the extension lower wire (95)
2. Lock the computer frame (4) on the upright tube (3L/R) with the hex socket screw (53) and Lock washer (83). Lock the hex socket screw (53) tightly which connect the bottom frame (1) and upright tube (3L/R).

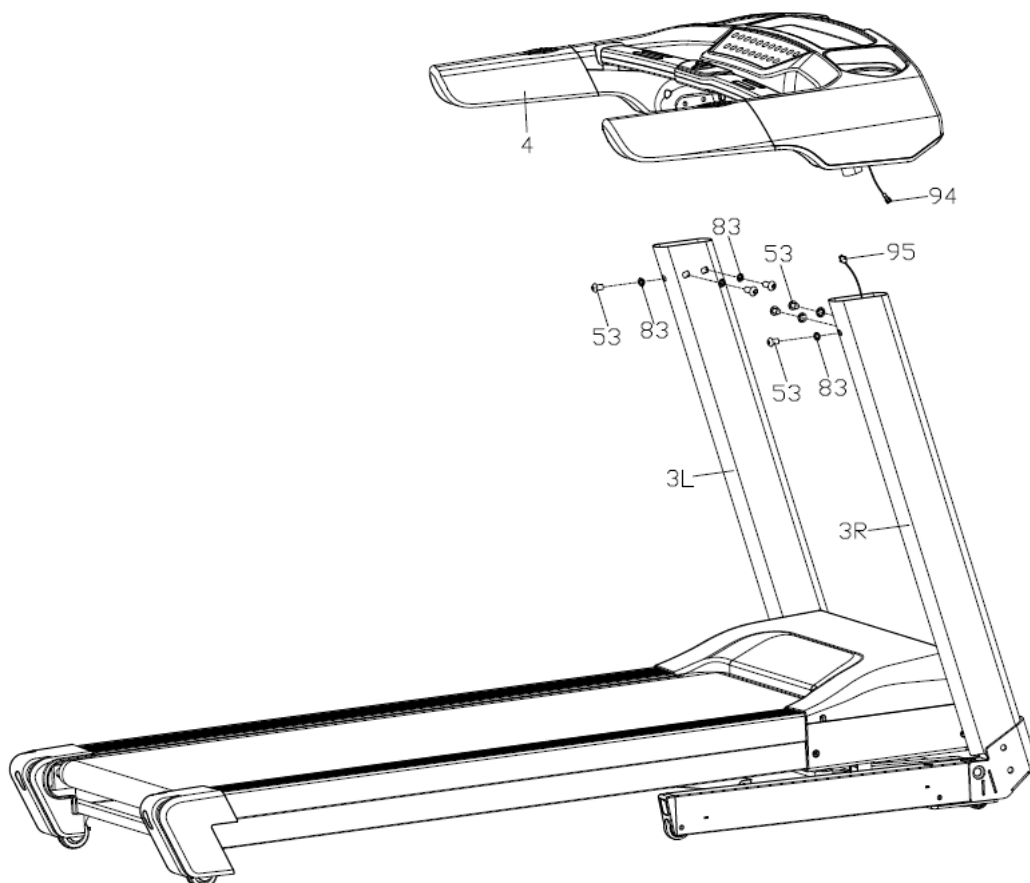

STEP 4:

1. As the picture 1 shown, connect the wires of computer board (33) with the wires of the computer frame (4).
2. Fix the computer board support frame (5) to the computer frame (4) with the hex bolt (57).
3. Fix the computer connects cover (36) to the computer upper cover (34) with the screw (73).

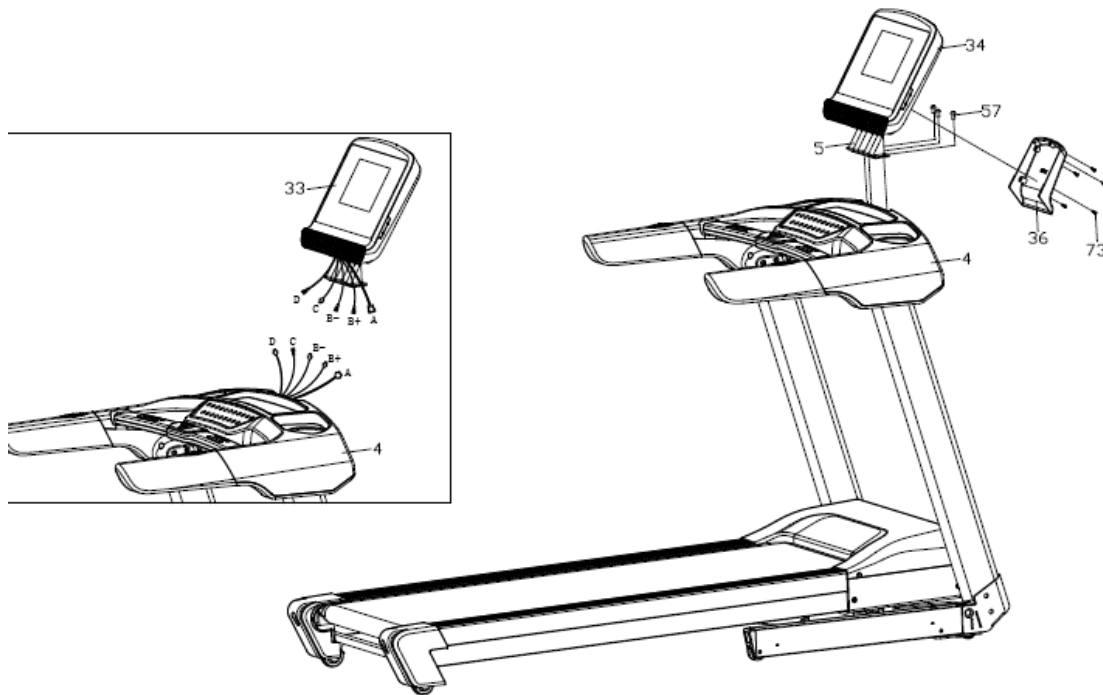

STEP 5:

1. Lock the Protective cover (32L / R) tightly to the Bottom frame (1) with Cross tapping screw(73).
2. insert the protective cover (32L/R) to the hole of the computer upper cover (20).

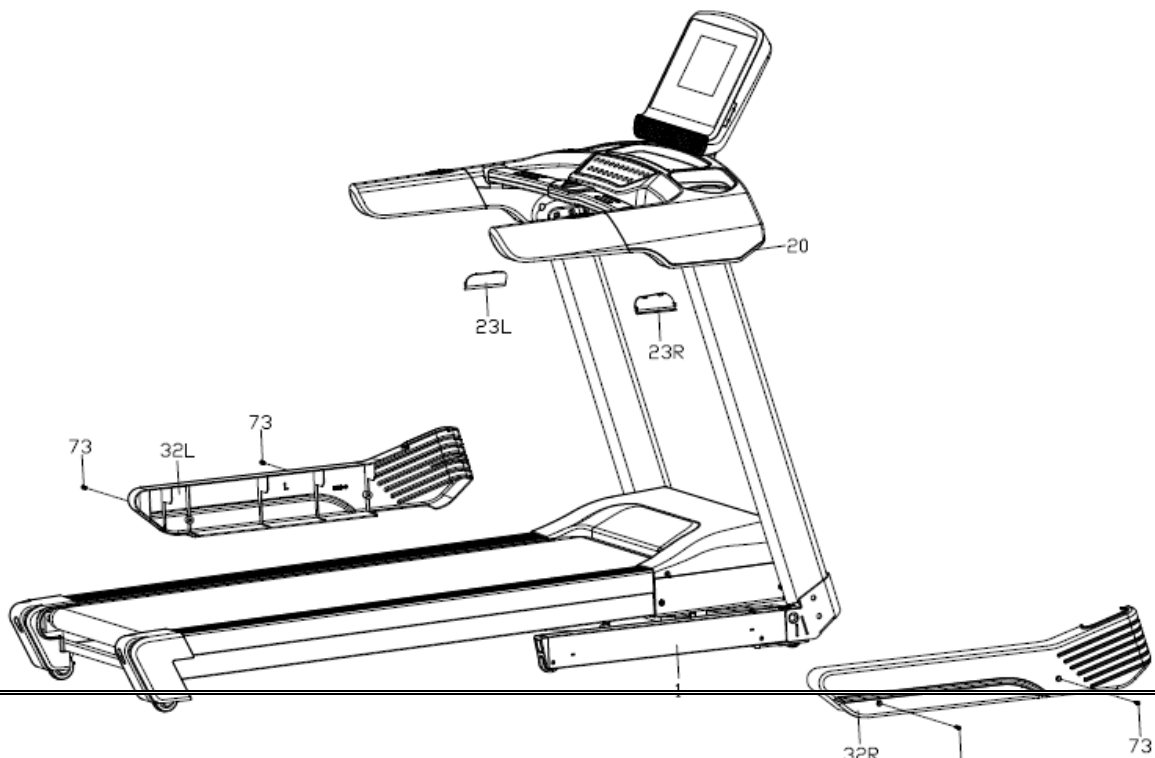

STEP 6:

When you fold the machine:

Put your hands on place **A**, lift up the machine in the direction of the arrow until you hear the sound from the cylinder (13).

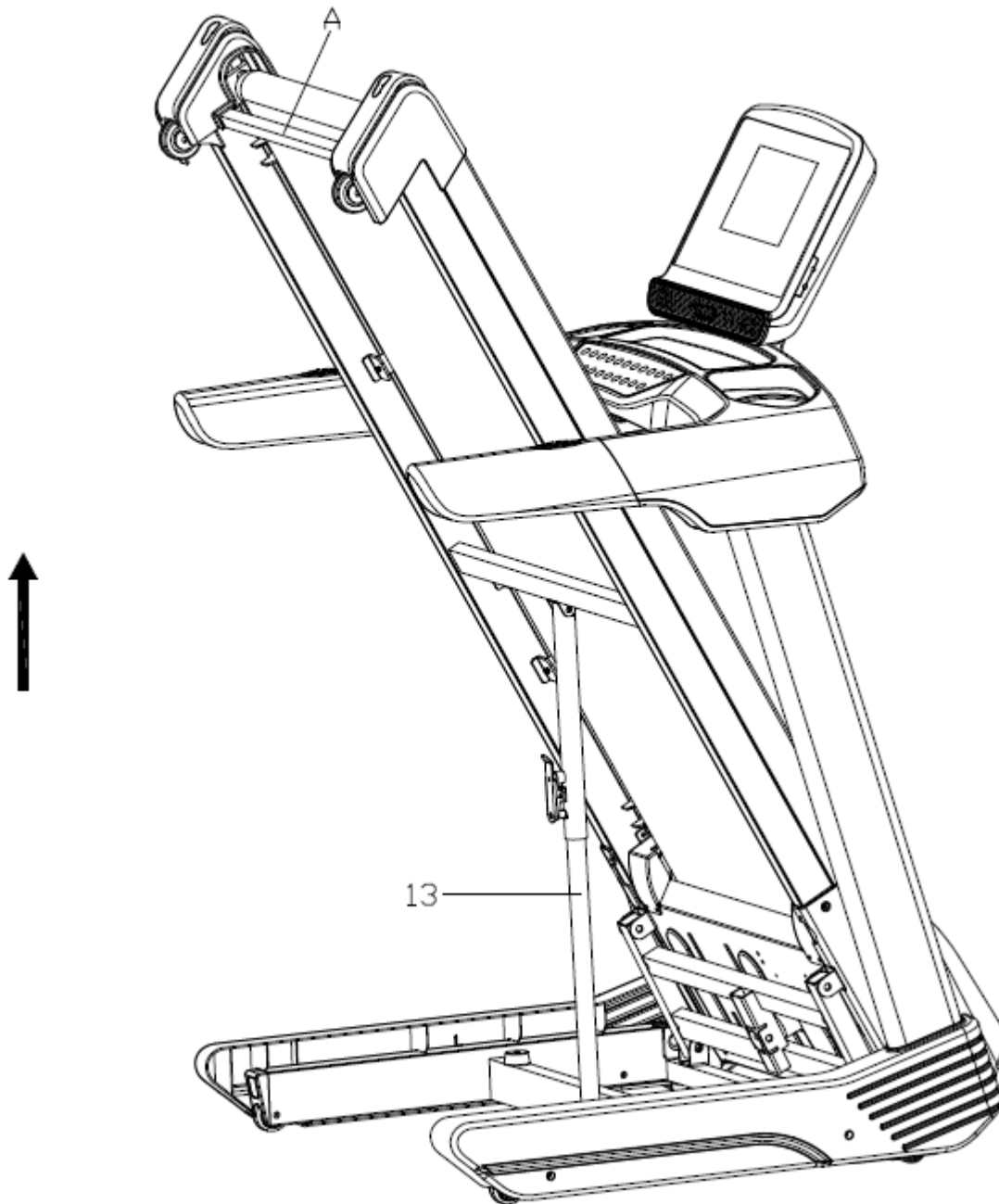

STEP 7:

When you unfold the machine:

Grasp the place **A** by one hand, kick the place **B** of cylinder (13) with your right foot, pull the running board to the level of place **C**, then the running board will get down automatically.

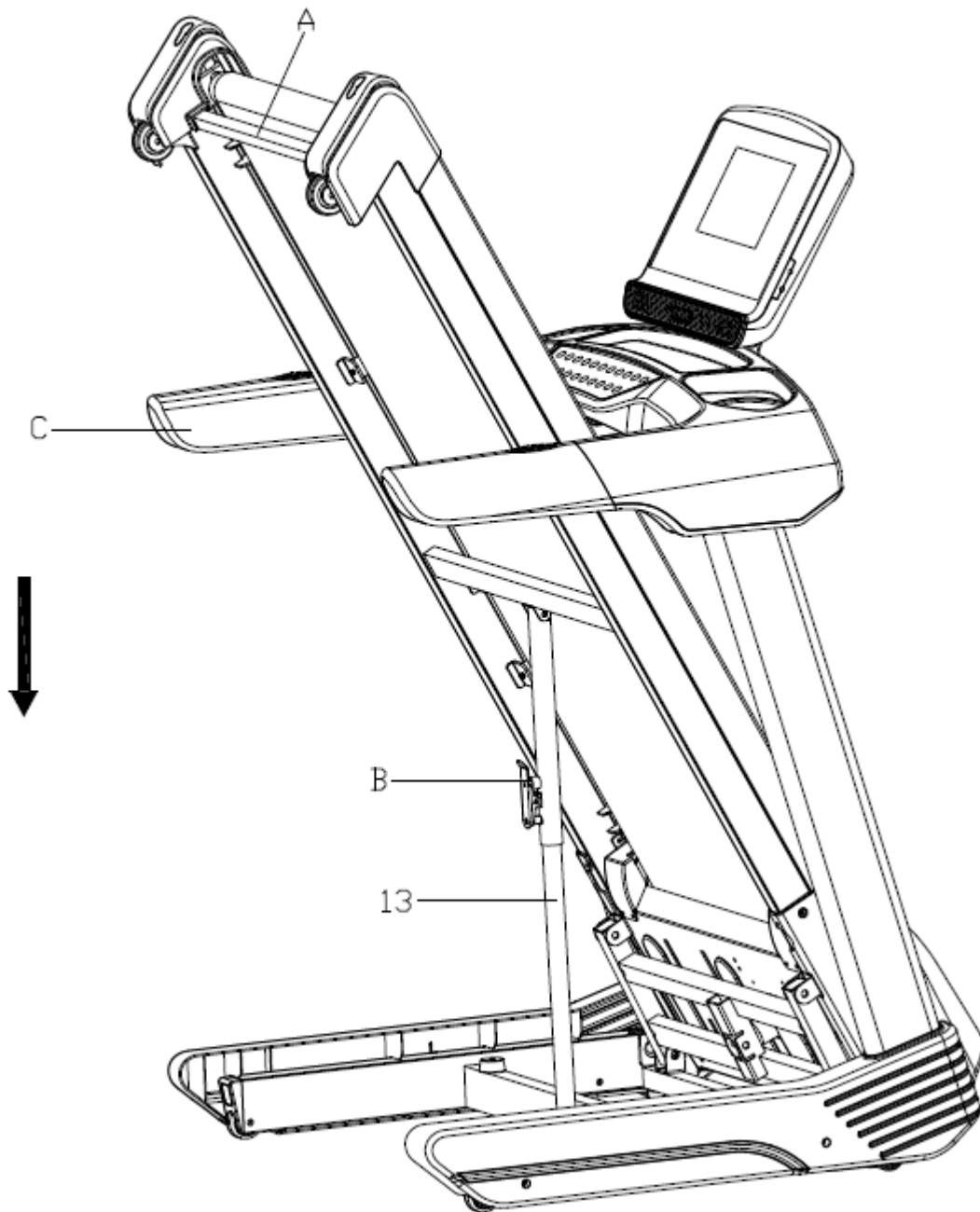

GROUNDING METHODS

This product must be grounded. If it should malfunction or breakdown, grounding provides a path of least resistance for electric current to reduce the risk of electric shock.

This product is equipped with a cord having an equipment-grounding conductor and a grounding plug. The plug must be plugged into an appropriate outlet that is properly installed and grounded in accordance with all local codes and ordinances.

DANGER – Improper connection of the equipment-grounding conductor can result in a risk of electric shock. Check with a qualified electrician or serviceman if you are in doubt as to whether the product is properly grounded.

Do not modify the plug provided with the product – if it will not fit the outlet, have a proper outlet installed by a qualified electrician.

This product is for use on a nominal 220-volt circuit and has a grounding plug that looks like the plug illustrated in **sketch A** in following figure. Make sure that the product is connected to an outlet having the same configuration as the plug.

No adapter should be used with this product.

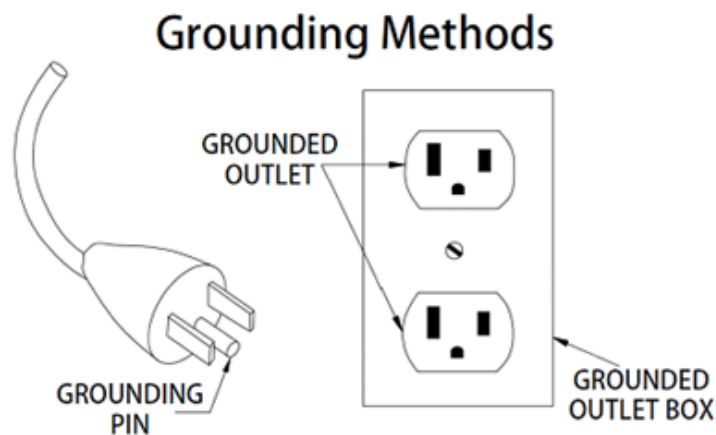

TECHNICAL PARAMETER

ASSEMBLY SIZE (mm)	1890*885*1490	POWER	AS ORDER
FOLDING SIZE (mm)	2300*885*1615	MAX OUTPUT POWER	AS ORDER
RUNNING SURFACE (mm)	500x1410	INPUT CURRENT	AS ORDER
NET WEIGHT	107KG	SPEED RANGE	1.0-20 KM/H
MAX WEIGHT	150 KG	INCLINE	0-15 level

OPERATION INSTRUCTIONS

1. Function specifications

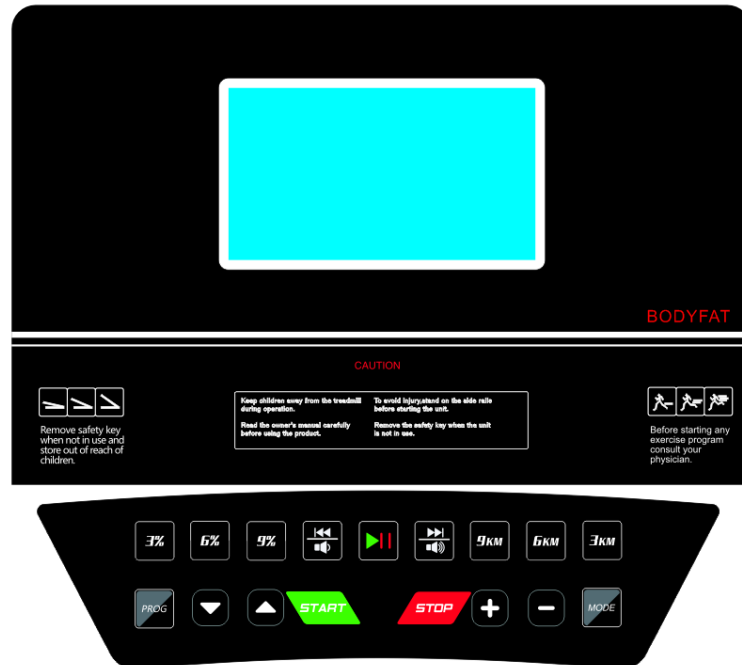

1.1. Start

Normal startup after 3s counting backwards.

1.2. Number of programs

Manual Modes, 18 Preset programs, 3 User setting programs, HRC1-HRC3, FAT.

1.3. Safe lock function

Remove the safety lock in any modes could rapidly slow down the treadmill till stop. "---" will be instantly displayed on the window, the buzzer buzz "Bi, Bi" sound continuously. Buttons are invalid in this condition. When the safety lock is off, at the same time press "PROG" + "MODE" key for 3s, the display switches between imperial and metric systems.

Restore the safety lock, the window will display for 2s and then get into standby state, wait for inputting commands.



1.4. LCD windows display functions:

A.Speed/pulse window:Display the current running speed or current pulse.

B.INCL./PROG. Window: Display the current incline or programs.

C.TIME Window:Display the running time under manual mode or the countdown running time under mode and programmed mode.

D.DIS./CAL./STEPS Window:display distance, calorie or steps data.Display Switch every 5 seconds.

E.window: “Lubrication” reminder. Display will light up the  icon when needed lubrication.

notice: Running steps valid in users when speed less than 3.0km/h or more than 16km/h, due to differences in user's weight and step rate.

1.5. Key function

START, STOP, PROG, MODE, SPEED/+/-, INCLINE/+/- .Speed shortcut: 3、6、9;
slop shortcut: 3%、6%、9%.

- ① “START” for startup, press START the treadmill will run at minimal speed; “STOP” for stop, the treadmill will stop when the key pressed.
- ② PROGRAM KEY: In standby state, you can circle select the programs from Manual Mode to “P1-P18, U1-U3,HRC1-HRC3 and FAT” by pressing this key; Manual model is set for default, the default speed is 1.0 km/h, max speed set at 20km/h.
- ③ MODE KEY: In standby state, press the key to select H-1 to H-3 three different countdown modes; H-1 for time countdown mode; H-2 for distance countdown mode; H-3 for cal. Countdown mode; SPEED/+/- key may be used to setup all the countdown modes, after setting the data, press the START to run the treadmill.
- ④ SPEED+/-: for increase or decrease the speed setting; when setting the parameters, the motor runs, the keys can be used as parameter adjuster, when the motor runs, the keys can be used as incline adjuster, up 0.1km per press; when continuously press over 0.5s, it will continuously speed up or down.
- ⑤ INCLINE+/-: “INCLINE+” and “INCLINE-” are for slop adjusting, which can be used for the data setting; when the treadmill is in use, the key can be used to adjust the slop, advance 1level per press; continuously press over 0.5s, it will continuously incline or decline.
- ⑥ SPEED shortcut: 3km/h, 6km/h, 9km/h can be set under operation condition.
- ⑦ INCLINE SHORTCUT:3,6,9 can be set under operation condition
- ⑧ VOLUME: adjust the music volume.
- ⑨ UP/NEXT: select the music truck.
- ⑩ Kilometer transform with mile: take off the safety key, press PROGRAM and MODE for three seconds at the same time.

1.6 Data display range of various parameters:

TIME: 0:00 – 99.59(MIN)

DISTANCE: 0.00 – 99.9(KM)

CALORIES: 0.0 – 999 (KCal)

SPEED: 1.0 – 20.0(KM/H)

PULSE: 50 – 200 (BPM)

INCLINE:0-15%

1.7. Heart rate measurement function

While the treadmill is connected to the power, hold the pulse tester for 5s and the heart rate value will be displayed. The initial value is the actually measured heart rate, and its display range is: 50-200 times/ minutes. In the heartbeat measurement process, there will be a heart shaped icon flashing.

Heart rate displayed is for reference only and can not be used as medical data.

1.8. Manual Modes

1.8.1. How to enter manual mode:

- A. Switch on the power supply; then, directly enter normal mode under the manual mode.
- B. In stop state, press MODE to select Normal mode, Time Countdown, Calorie Countdown and Distance Countdown modes under the manual mode.

1.8.2. Setting functions under manual mode: Time, Distance and Calorie Setting

- A. When entering the manual mode, the time is displayed as 0:00;
- B. In manual mode, press MODE to enter **Time Countdown mode**; the time window will display the time and flicker; the initial time is 30:00; set countdown time by SPEED +/- SPEED -. Time setting range: 5:00-99:00; each time of increase/ decrease will be 1: 00.
- C. In time countdown mode, press MODE to enter **Distance Countdown mode**; the initial distance will be displayed as 1.00 km; set the distance by SPEED +/- SPEED - in the range of 1.0-99.0 km/mi; each time of increase/ decrease will be 1 km.
- D. In distance countdown mode, press MODE to enter **Calorie Countdown mode**; the initial distance will be displayed as 50.0kcal; set the calorie by SPEED +/- SPEED - in the range of 20.0-990.0 kcal; each time of increase/ decrease will be 10.0 kcal.

1.8.3. Operation in manual mode:

- A. Press START and the motor will start operating after 3s of countdown; the initial speed will be 1.0km/h for metric system or 0.6mile/h for imperial system;
- B. Press SPEED +/- SPEED - to adjust speed;
- C. Press speed shortcuts to quickly set up to the speed marked on the key;
- D. When the motor is running, press STOP and the motor will slow down and stop finally;
- E. Remove the safety lock to urgently stop motor running; then, LCD window will display “---” and the buzzer will make short sound of Bi-Bi-Bi.
- F. When the set time reduces to zero or when the set calorie reduces to zero, or the set distance reduces to zero, the speed will gradually reduce till the stop of the machine, the buzzer will make short alarm “Bi-Bi-Bi”, and the speed window will display END; 5s later, the machine will return to the standby state and the buzzer will make long alarm “Bi-Bi”;
- G. Parameters not set will increase forwards, and will be reset after reaching the upper limit of the display range; in manual mode, the machine will stop when the time accumulates to be more than 99: 59 (100min).

1.9. Preset Programs

Each program is divided into 16 sections; the operation time will be evenly distributed to each program section. Here below is a 18section program running diagram.

No.		Setup time / 16 = each segment of the running time															
		1	2	3	4	5	6	7	8	9	10	11	12	13	14	15	16
P1	SPEED	2	5	5	5	10	10	5	5	5	3	3	2	5	5	3	2
	INCLINE	0	0	1	1	1	1	2	2	2	2	3	3	3	2	2	0
P2	SPEED	2	2	7	2	2	7	7	12	4	4	12	4	4	12	4	2
	INCLINE	0	1	2	2	3	3	2	2	3	3	2	2	3	2	2	0
P3	SPEED	2	4	9	9	4	4	8	8	10	10	12	4	4	8	4	2
	INCLINE	0	1	2	3	4	5	4	5	4	2	1	2	3	2	1	0
P4	SPEED	2	6	6	6	12	12	12	12	6	6	3	3	3	5	5	2
	INCLINE	0	1	2	3	4	5	6	7	6	6	5	4	3	2	1	0
P5	SPEED	2	4	6	12	12	12	3	3	3	3	12	12	12	6	4	2
	INCLINE	0	2	4	6	4	2	1	0	1	1	2	2	2	2	3	0
P6	SPEED	2	4	5	5	6	6	8	8	6	6	8	8	6	9	6	2
	INCLINE	0	1	3	4	4	3	3	1	2	1	2	1	2	1	2	0
P7	SPEED	2	7	7	9	9	4	4	12	12	4	4	8	8	4	4	2
	INCLINE	0	1	1	2	2	3	3	4	4	3	3	2	2	1	1	0
P8	SPEED	2	2	6	6	6	8	9	10	11	12	9	5	5	5	3	2
	INCLINE	0	1	2	4	2	1	2	4	2	1	2	4	2	1	2	0
P9	SPEED	2	4	8	10	2	4	8	10	2	4	10	2	4	10	4	2
	INCLINE	0	1	2	3	4	5	6	7	8	9	8	6	4	2	1	0
P10	SPEED	2	5	6	7	8	9	10	11	10	9	8	6	7	5	4	2
	INCLINE	0	1	2	4	6	6	6	4	4	4	2	2	2	1	1	0
P11	SPEED	2	5	6	7	9	9	6	9	6	9	6	10	6	10	7	2
	INCLINE	0	2	2	2	3	3	3	4	4	4	5	5	5	4	4	0
P12	SPEED	2	6	8	10	8	6	4	6	8	12	8	6	8	12	12	2
	INCLINE	0	1	1	3	3	5	5	7	7	5	5	3	3	1	1	0
P13	SPEED	2	12	4	12	4	12	4	12	4	12	4	12	4	12	4	2
	INCLINE	0	8	10	13	4	8	10	13	4	8	10	13	4	8	10	0
P14	SPEED	2	8	10	12	4	8	10	12	4	8	10	12	4	8	10	2
	INCLINE	0	8	12	13	4	8	12	13	4	8	12	13	4	8	12	0
P15	SPEED	2	12	10	8	12	12	10	8	12	12	10	8	12	12	10	2
	INCLINE	0	3	4	5	6	8	7	8	8	7	7	6	5	4	3	0
P16	SPEED	2	12	4	12	4	12	4	12	4	12	4	12	4	12	4	2
	INCLINE	0	4	5	6	2	4	5	6	2	4	5	6	2	4	5	0
P17	SPEED	2	4	6	8	10	12	12	2	4	6	8	12	12	10	6	2
	INCLINE	0	4	6	8	10	12	13	12	13	12	13	10	8	6	4	0
P18	SPEED	2	6	8	4	6	8	4	6	8	4	6	8	4	6	8	2
	INCLINE	0	6	8	2	6	8	1	6	8	2	6	8	1	6	8	0

1.10. User-setting programs:

Beside the 18 inner systems, the treadmill setup 3 user-defined programs: U1, U2, U3.

1. Setting the user-defined program:

Continuously press "PROG" key until the expected program (U1/U2/U3) display in the standby condition, while the "time" window flash, display the setting time, press "SPEED+", "SPEED -" to set up expected run time, press "MODE" key to enter program parameter, then set up the first time period parameter, by " SPEED +" /" SPEED -" key or shortcut key to set the speed; press "mode" key to finish the first time period setting, and entering the next time period setting, until all 16 time period setting. The parameter will be kept permanently until resetting, and all parameter will not be lost when power off.

2. Selection and start the user-defined program:

In the standby condition, continuously press "PROG" key until the expected user-defined program U1/U2/U3 display, set up the run time, press "start" key to turn on the treadmill.

1.11. Body Fat Test:

In standby state, press PROG to enter FAT (Physical fitness test) program. Press MODE to enter the program of F—1, F—2, F—3, F—4, F—5 (F—1:gender, F—2:age, F—3:height, F—4:weight, F—5:physical test), Press SPEED +/ SPEED - to set the parameter of 01-04(see below detailed table), then press MODE to enter the program of F—5 for physical test. At this state, hold the handle pulse board for 5-6 seconds and it will display the FAT, check if the weight matches with your height.

FAT is to measure the relevance between height and weight, not the body proportion. FAT is suitable for every man and woman, it provide the important grounds for adjusting the weight with other health indicators. The perfect FAT is between 20-24, which means if less than 19 is too thin, and if between 25-29 is overweight and if more than 30 is obesity.

F--1	Gender	01(man)	02(woman)
F--2	Age	10-----99	
F--3	Height	100-----200	
F--4	Weight	20-----200	
F--5	FAT	≤19	Underweight
	FAT	=(20--24)	Normalweight
	FAT	=(25--29)	Overweight
	FAT	≥30	Obesity

1.12.HRC:

DEFAULT is a particular set of instructions which the computer always uses unless the person using the computer gives other instructions.

Lowest-Highest: the adjustable range in the heart rate from the lowest to the highest.

HRC program							
AGE	Target zone (L-H)			AGE	Target zone (L-H)		
	lowest	default	highest		lowest	default	highest
15	170	175	180	48	137	142	147

16	169	174	179	49	136	141	146
17	168	173	178	50	135	140	145
18	167	172	177	51	134	139	144
19	166	171	176	52	133	138	143
20	165	170	175	53	132	137	142
21	164	169	174	54	131	136	141
22	163	168	173	55	130	135	140
23	162	167	172	56	129	134	139
24	161	166	171	57	128	133	138
25	160	165	170	58	127	132	137
26	159	164	169	59	126	131	136
27	158	163	168	60	125	130	135
28	157	162	167	61	124	129	134
29	156	161	166	62	123	128	133
30	155	160	165	63	122	127	132
31	154	159	164	64	121	126	131
32	153	158	163	65	120	125	130
33	152	157	162	66	119	124	129
34	151	156	161	67	118	123	128
35	150	155	160	68	117	122	127
36	149	154	159	69	116	121	126
37	148	153	158	70	115	120	125
38	147	152	157	71	114	119	124
39	146	151	156	72	113	118	123
40	145	150	155	73	112	117	122
41	144	149	154	74	111	116	121
42	143	148	153	75	110	115	120
43	142	147	152	76	109	114	119
44	141	146	151	77	108	113	118
45	140	145	150	78	107	112	117
46	139	144	149	79	106	111	116
47	138	143	148	80	105	110	115

a) The movement time of the heart rate speed was fixed at 22 minutes.

b) In standby mode, press "PROGRAM" key continually until the distance window displays "HRC".

Notes: If press "START" key directly under the HRC display window, the system will automatically recommend a heart rate control parameter for the user as following: HRC can reach a maximum speed of 9.0 km/H, age 30 years, the default setting is 160times/minute.

c) if press "MODE" key to enter age Settings, the speed window will display default age 30. The user can press "SPEED+, SPEED-" key or "INCLINE+, INCLINE-" key to choose the right age which is suitable. The adjustable age range is 15-80 years old. (The details please see the HRC form)

c) After the user chooses the right age, press “MODE” key, the system will automatically recommend a right target heart rate according to the chosen age displaying on the speed window for reference. Also the user can choose the target heart rate on the basis of personal physical condition by pressing “SPEED+,SPEED-”key or“INCLINE+,INCLINE-”key. The select range is 95-180(The details please see the HRC form)

d) After the user chose the age and target heart rate, press “MODE” key into the home screen.

e)On the state of HRC, pressing “SPEED+,SPEED-”key or“INCLINE+,INCLINE-”key can adjust the speed and incline, but the system will automatically adjust the speed and incline to make your heart rate close the target heart rate.

f) The front 3 minutes before movement is warm-up time, the system will not automatically adjust the speed and incline but only manually adjust; After 3 minutes, the system will adjust according to your current heart rate.

When the user’s actual heart rate<target heart rate, HRC will automatically increase 0.5KM/time per 10S until the specified maximum speed. (At this moment, the user can control the incline freely.)

When the user’s actual heart rate>target heart rate, HRC will automatically reduce 0.5KM/time per 10S until the minimum speed of HP2. (At this moment, the user can control the incline freely.)

When the movement time exceeds 20 minutes , the system will enter into “COOLDOWN”mode and the incline go to zero and the speed lower 0.5KM/H per 10 seconds. When the speed lower to 4KM/H or less, the speed stops lowering until the movement ends. You can directly press “STOP” key or switch off the safety key to stop the movement.

Notes: 1.HRC must use the chest belt to detect the heart rate and the chest belt must close to the chest and skin.

2. The data collection may be imprecise while using HRC with music playing.

1.13. Others

1.13.1. When a countdown parameter run off, display "END", the alarm rings 0.5s every 2s, until the treadmill full stop, then return to manual mode.

1.13.2. In setting a parameter, it can be roop-setting, for example, time range is 5:00--99:00, when set at 99:00, press "+" key, the time return to 5:00, and so on recirculation, add or reduce by "+"“—”symbol.

1.13.3. Countdown time, countdown calorie and countdown distance can only be set up for one of them. The last time setting will be implemented. The parameter set will be counted backwards while other parameters will be counted forwards.

1.13.4. The standard calorie is about 70.3kcal/km.

1.13.5. The acceleration is 0.5Km/S and the deceleration is 0.5Km/S.

1.13.6. MP3 music audio amplification, input from the enter hole by the side.

1.13.7. In the process the un-set parameter will be up cumulative, the display clear when up to the max range; in the manual mode when the time accumulation excess 99:59(100min) the treadmill stops.

1.14. “Lubrication” reminder:

Treadmill

total working

after Every 300KM, the screen will light up the  icon. Standby, remove the safety key then hold the “ Speed + ” and "Speed -" button simultaneously till “Bi Bi” buzz comes will cancel this reminder. 300KMs later,the loop runs again.

1.15. Meanings of error message codes

Problem	Potential reasons	Solutions
-----	Safe lock falls down	<ol style="list-style-type: none"> 1. Place back the safe lock; 2. Replace safe lock switch or magnetic sensor in the electronic meter; if the problem still fails to be solved, replace the electronic meter;
E01	<p>After powering on, the electronic meter displays E01</p> <p>Communication failure from the electronic meter to the driver, The electronic meter displays E01 in the operating process</p> <p>Communication failure from the driver to the electronic meter</p>	<ol style="list-style-type: none"> 1. Check whether the connecting joint between the electronic meter and the core wire of the controller is loose; whether wires are damaged; whether the core wires are in correct connecting order. 2. The controller may be defective. Check and replace a good one. 3. The electronic controller’s IC may not be plugged to the place. Check and ensure good plugging. 4. The transformer may be damaged. Check and replace a

		good one.
E02	Explosion-proof protection or motor abnormality	<p>1. Check whether the power supply voltage is less than 50% of the normal value; please ensure correct voltage and test again;</p> <p>2 Check whether motor wires are well connected; re-connect motor wires, or, if the problem still fails to be solved, replace the motor;</p> <p>3. Check whether there is peculiar odor generated by the controller; if yes, it means that IGBT has been broken down to cause short circuit; then, replace the controller.</p>
E03	No sensory signal	Check whether the photoelectric sensor directs to the hole on CD; check whether wires of photoelectric sensor are damaged and whether terminals of the photoelectric sensor and speed terminals on the controller are firmly connected.
E04	Lifting learning or self-inspection fails	<p>1. Check whether motor signal wires are well inserted; re-insert the signal wire joint to ensure that it is reliable;</p> <p>2. Check whether lifting motor's AC wires are properly connected; lifting motor shall be correctly plugged according to marks on its AC controller;</p> <p>3. Check whether motor wiring is damaged to form open circuit; if yes, replace wires or replace the lifting motor;</p> <p>4. Replace the controller;</p> <p>5. After all of these inspections, press the learning key for learning again.</p>
E05	Over-current protection	<p>1. It may be the system's self-protection against excessive current when the load exceeds the rated value; restart the machine;</p> <p>2. Some part of the treadmill is jammed so that the motor can not rotate, thus triggering the self-protection of the system against excessive current under excessive load; adjust the treadmill and restart it, or add lubricant.</p> <p>3. Check whether there is over-current sound or burning odor when the motor is running; replace the motor;</p> <p>4. Check whether the controller emits the odor of burning; if yes, replace the controller.</p>
E06	Lifting sensor has no signal	<p>1. Check whether lifting signal wires are damaged.</p> <p>2. Check whether lifting signal terminals and the controller's lifting terminals are firmly connected.</p> <p>3. Check whether lifting power cords are damaged.</p> <p>4. Check whether lifting power cord terminals and the controller's lifting terminals are firmly connected.</p>
No display on the electronic meter	The controller is not powered on or is damaged	<p>1. First of all, check whether the over-load protector has tripped off; if yes, press it;</p> <p>2. Check the power supply switch, over-load protector and the controller's power cord and transformer to ensure well connection;</p> <p>3. Check whether the power cords from the electronic meter to the controller are well collected; dismantle the pillar to check connecting joints on each section of the wiring from the electronic meter to the controller; ensure that each wire core</p>

is well connected; or the reason may be the communication power cord defect (damaged or broke down); in such case, re-connect or replace wires.

4. The transformer is damaged; replace the transformer

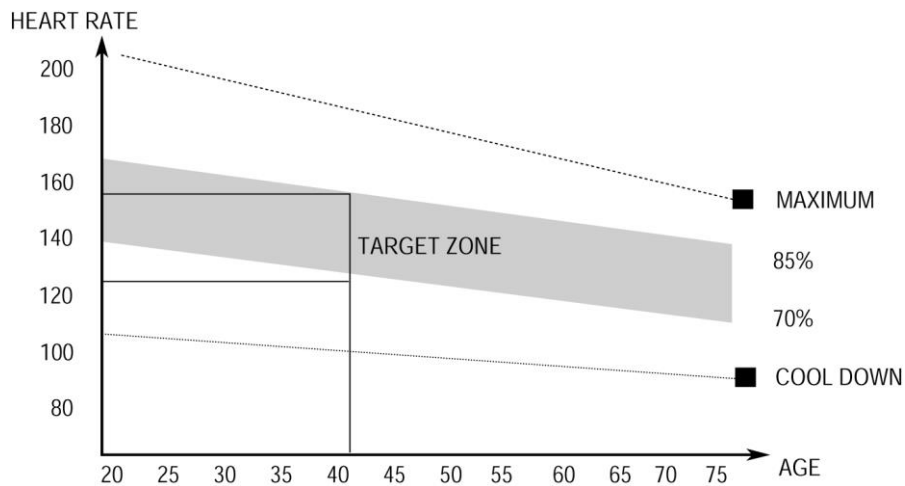

EXERCISE INSTRUCTIONS

1. The Warm Up Phase

This stage helps get the blood flowing around the body and the muscles working properly. It will also reduce the risk of cramp and muscle injury. It is advisable to do a few stretching exercises as shown below. Each stretch should be held for approximately 30 seconds, do not force or jerk your muscles into a stretch - if it hurts, **STOP**.

2. The Exercise Phase

This is the stage where you put the effort in. After regular use, the muscles in your legs will become Stronger. Work to your but it is very important to maintain a steady tempo throughout. The rate of work should be sufficient to raise your heart beat into the target zone shown on the graph below.

This stage should last for a minimum of 12 minutes though most people start at about 15-20 minutes

3. The Cool Down Phase

This stage is to let your Cardio-vascular System and muscles wind down. This is a repeat of the warm up exercise e.g. reduce your tempo, continue for approximately 5 minutes. The stretching exercises should now be repeated, again remembering not to force or jerk your muscles into the stretch.

As you get fitter you may need to train longer and harder. It is advisable to train at least three times a week, and if possible space your workouts evenly throughout the week.

To tone muscle while on your Treadmill you will need to have the resistance set quite high. This will put more strain on our leg muscles and may mean you cannot train for as long as you would like. If you are also trying to improve your fitness you need to alter your training program. You should

train as normal during the warm up and cool down phases, but towards the end of the exercise phase you should increase resistance, making your legs work harder than normal. You may have to reduce your speed to keep your heart rate in the target zone.

The important factor here is the amount of effort you put in. The harder and longer you work the more calories you will burn. Effectively this is the same as if you were training to improve your fitness, the difference is the goal.

MAINTENANCE INSTRUCTIONS

WALKING BELT CENTERING AND TENSION ADJUSTMENT

DO NOT OVERTIGHTEN the walking belt. This may cause reduced motor performance and excessive roller wear.

TO CENTER WALKING BELT:

- Place treadmill on a level surface
- Run treadmill at approximately 3.5 mph
- If the belt drifts to the right side, please screw the right adjusting bolt clockwise slowly, noticing the change of the deviating distance, until center the belt. (Attention: the space between the belt and the right/left edgings is at a distance normally. And the gap between the right and left distance should be no more than 5mm.
- If the belt drifts to the left side, please screw the left adjusting bolt clockwise slowly, noticing the change of the deviating distance, until center the belt. (Attention: the space between the belt and the right/left edgings is at a distance normally. And the gap between the right and left distance should be no more than 5mm.

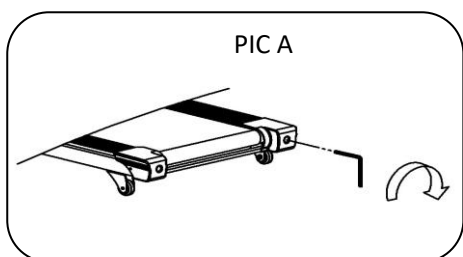

Picture A: If the belt has drifted to the LEFT

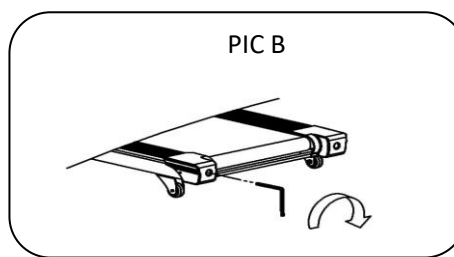

Picture B: If the belt has drifted to the RIGHT

WARNING: ALWAYS UNPLUG THE TREADMILL FROM THE ELECTRICAL OUTLET BEFORE CLEANING OR SERVICING THE UNIT.

CLEANING

General cleaning of the unit will greatly prolong the treadmill. Keep treadmill clean by dusting regularly.

Be sure to clean the exposed part of the deck on either side of the walking belt and also the side rails.

This reduces the build up of foreign material underneath the walking belt.

The top of the belt may be cleaned with a wet, soapy cloth. Be careful to keep liquid away from inside the motorized treadmill frame or from underneath the belt. **Warning: Always unplug the treadmill from the electrical outlet before removing the motor cover.** At least once a year remove the motor cover and vacuum under the motor cover.

WALKING BELT AND DECK LUBRICATION

This treadmill is equipped with a pre-lubricated, low maintenance deck system. The belt/ deck friction may play a major role in the function and life of your treadmill, thus requiring periodic lubrication. We recommend a periodic inspection of the deck.

We recommend lubrication of the deck according to the following timetable:

- **Light user (less than 3 hours/ week)** **annually**
- **Medium user (3-5 hours/ week)** **every six months**
- **Heavy user (more than 5 hours/ week)** **every three months**
-

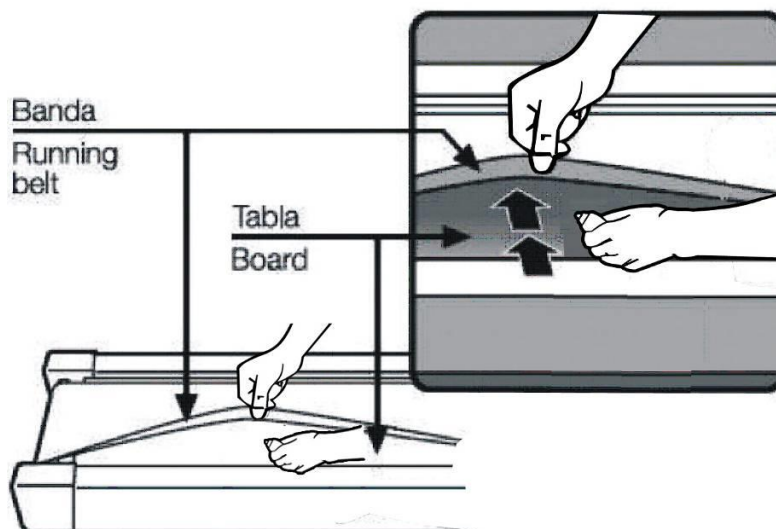

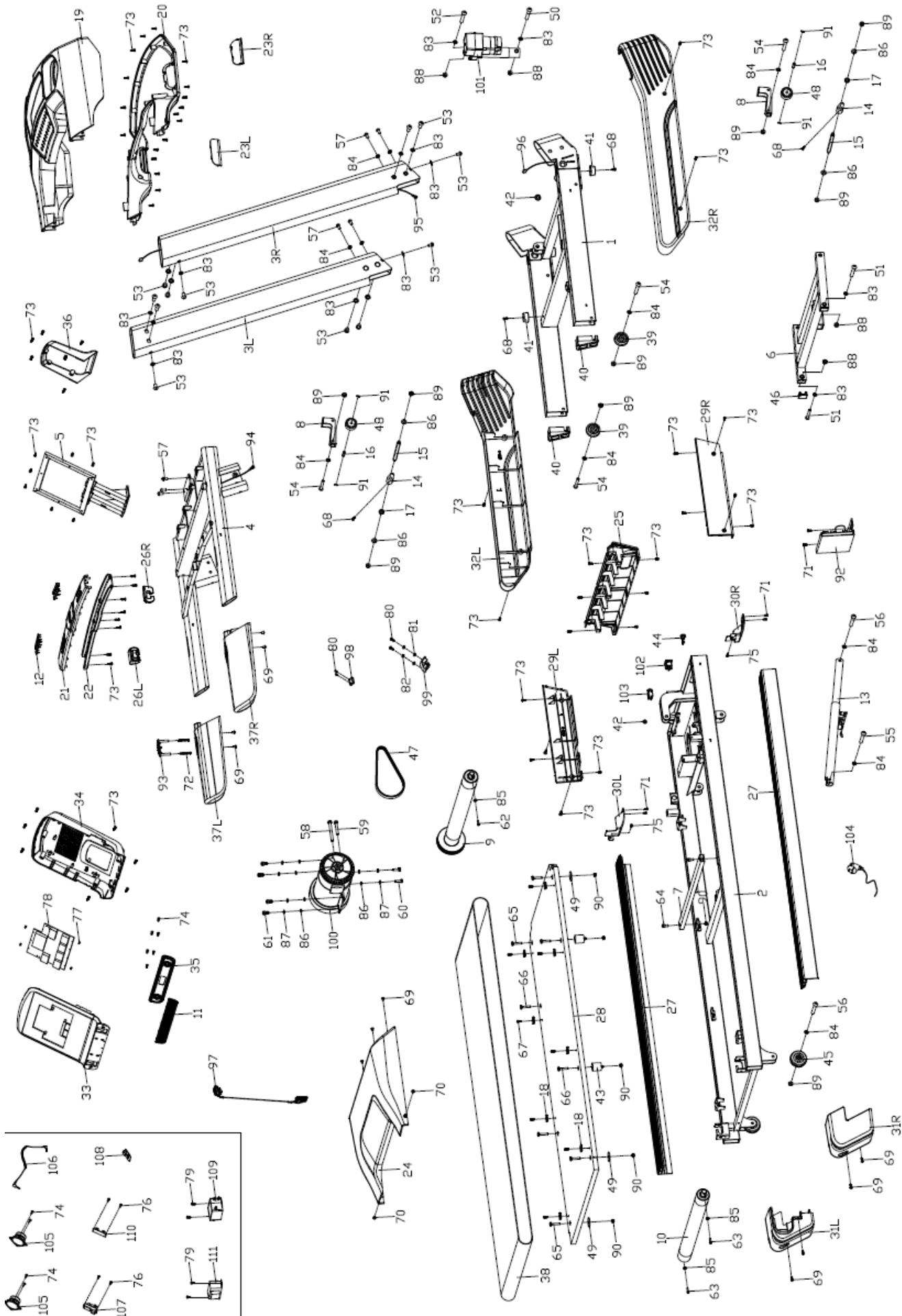

EXPLODED DRAWING

PARTS LIST

Part No.	Description	Qty	Part No.	Description	Qty
1	Bottom frame	1	57	Hex screw M8*15	7
2	Main frame	1	58	Hex screw M8*55	1
3L/R	Upright tube	2	59	Hex screw M8*40	1
4	Computer frame	1	60	Hex screw M8*15	2
5	Computer board support frame	1	61	Socket cap screw M8*18	4
6	Incline frame	1	62	Socket cap screw M6*45	1
7	Strengthen tube	1	63	Socket cap screw M6*55	2
8	Transport wheel bracket	2	64	Socket cap screw M6*10	2
9	Front roller	1	65	Screw M6*30	4
10	Rear roller	1	66	Screw M6*25	4
11	Metal speaker grille	1	67	Screw M5*25	8
12	Heart rate pulse	4	68	Cross pan head screw M6*15	6
13	Cylinder	1	69	Cross pan head screw M5*16	11
14	Transport wheel stopper	2	70	Cross pan head screw M5*8	2
15	D-shaped axle	2	71	Cross pan head screw M4*8	6
16	Transport wheel axle	2	72	Cross tapping screw ST4*55	4
17	Spacer	2	73	Cross tapping screw ST4*16	77
18	Edgings pressing plate	8	74	Cross tapping screw ST4*12	10
19	Computer up cover	1	75	Cross tapping screw ST4*12	2
20	Computer bottom cover	1	76	Cross tapping screw ST2.9*9.5	4
21	Front Handlebar bottom cover	1	77	Cross tapping screw ST2.6*10	4
22	Front Handlebar up cover	1	78	Computer	1
23L/R	Upright tube protective cover	2	79	Cross screw M4*8	4
24	Motor cover	1	80	Cross tapping screw ST2.9*6	4
25	Protective cover	1	81	Flat washer D4	2
26L/R	Protective cover	1pr.	82	Spring washer D4	2
27	Edgings	2	83	Lock washer Φ 10*1.2	16
28	Running board	1	84	Lock washer Φ 8*1.2	12
29L/R	Protective cover	1pr.	85	Lock washer Φ 6*1.2	3
30 L/R	Protective cover	1pr.	86	Flat washer Φ 13* Φ 8*1.2	10
31 L/R	Protective cover	1pr.	87	Spring washer Φ 8	6
32 L/R	Protective cover	1pr.	88	Nylon nut M10	4
33	Computer board	1	89	Nylon nut M8	10
34	Computer board upper cover	1	90	Nylon nut M6	10
35	Metal speaker cover	1	91	Snap ring Φ 8	4
36	computer connects cover	1	92	Converter	1
37L/R	PU foam grip	1 pr	93	Computer connecting wire	1
38	Running belt	1	94	Extension upper wire	1
39	Transport wheel	2	95	Extension lower wire	1
40	Transport wheel cap	2	96	Controller wire	1

41	Flat foot pad	2	97	Safety key	1
42	Wire plug	2	98	Optical detector	1
43	Cushion	4	99	Optical detector support	1
44	Power wire buckle	1	100	DC motor	1
45	Adjusting wheel	2	101	Incline motor	1
46	Square end cap	2	102	Switch	1
47	Belt	1	103	Circuit breaker	1
48	Wheel	2	104	Power wire	1
49	Plastic pad	4	105	Loudspeaker (Optional)	2
50	Hex socket screw M10*55	1	106	Amplifier board (optional)	1
51	Hex socket screw M10*50	2	107	USB (Optional)	1
52	Hex socket screw M10*40	1	108	Bluetooth (Optional)	1
53	Hex socket screw M10*15	12	109	Filter (Optional)	1
54	Hex socket screw M8*50	4	110	MP3 connecting wire/ Headphone jack (Optional)	1
55	Hex socket screw M8*45	1	111	Inductor (Optional)	1
56	Hex socket screw M8*40	3			